



# TD SERIES 3-PHASE, 3-WIRE FILTERS

## COMPONENTS

PART NO.	Cx (uF)	Cy (pF)	L1 (uH)	L2 (mH)	R (KΩ)
10TDS6D	0.22	2200	122	2.8	500
20TDS6D			78	1.6	
30TDS6D			40	0.9	
40TDS6D			32	1.1	
50TDS6D			14	0.6	

## INTRODUCTIONS

1. Applications: Electric equipment, UPS, machine tool, copy machine, automation equipment, robot, AC motor drive
2. Voltage rating: 440VAC
3. Operating frequency: 50/60Hz

## MINIMUM INSERTION LOSS IN dB

COMMON MODE (L-G) IN 50 OHM SYSTEM							
TYPE	CURRENT RATING	FREQUENCY - MHz					
		.15	.50	1.0	5.0	10	30
10TDS6D	10A	25	35	40	40	40	25
20TDS6D	20A	15	30	30	35	25	20
30TDS6D	30A	15	20	30	40	40	25
40TDS6D	40A	20	30	30	35	40	30
50TDS6D	50A	10	20	20	35	35	35
DIFFERENTIAL MODE (L-L) IN 50 OHM SYSTEM							
10TDS6D	10A	15	35	45	45	45	30
20TDS6D	20A	10	30	40	40	30	20
30TDS6D	30A	10	20	30	40	30	20
40TDS6D	40A	10	20	30	35	40	35
50TDS6D	50A	8	20	30	35	35	35

## ELECTRICAL SCHEMATIC

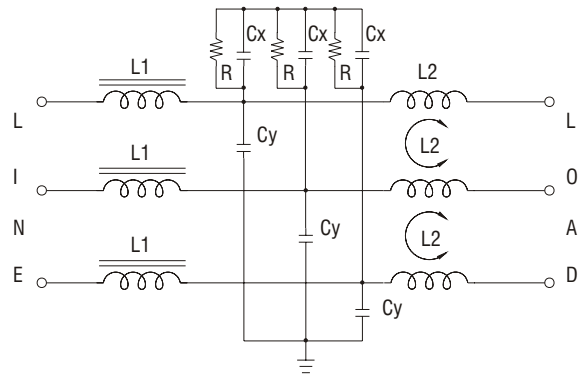

## SERIES DIMENSIONS

DIM. TYPE	A	B	C	D	E	F	G	H	I	J
10TDS6D	7.16	6.692	2.36	6.69	4.80	5.314	5.98	1.37	2.63	M6X1.0
	182.0	170.0	60.0	170.0	122.0	135.0	152.0	35.0	67.0	
20TDS6D	7.16	6.692	2.36	6.69	4.80	5.314	5.98	1.37	2.63	
30TDS6D	182.0	170.0	60.0	175.0	122.0	135.0	152.0	35.0	67.0	
40TDS6D	7.16	6.299	1.96	10.23	7.95	8.661	9.52	1.57	3.22	
50TDS6D	182.0	160.0	50.0	260.0	202.0	220.0	242.0	40.0	82.0	

## MECHANICAL CONSTRUCTION



Terminal cover: (Optional)

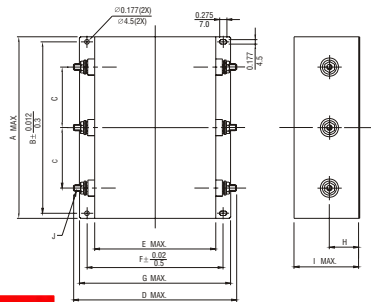
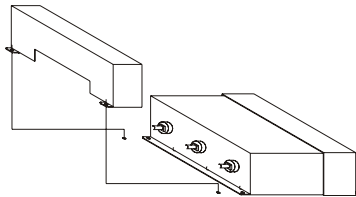

**大豪电子**  
 电话: 0755-83233025  
<http://www.szdahao.com>  
<http://www.very-tec.com>

UNIT: INCH/mm